

DATA SHEET

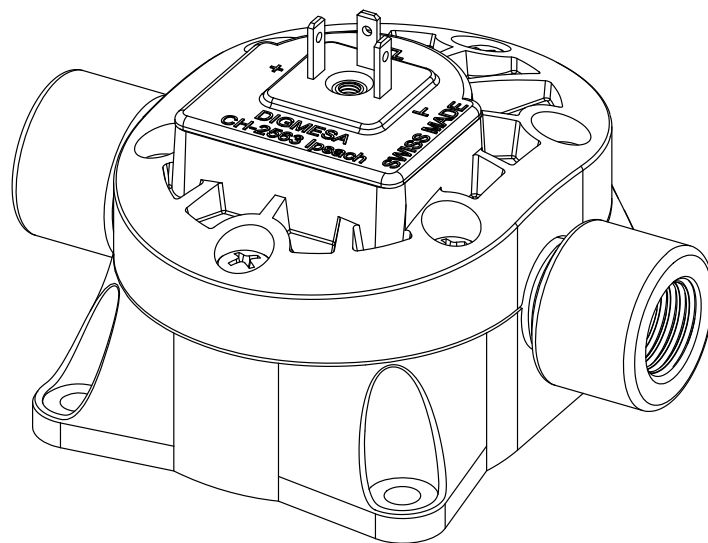

DIGIMESA⁺
CHOOSE THE ORIGINAL

EPI PEEK
Part number: 930-0201-V01

Digimesa AG, Keltenstrasse 31, CH-2563 Ipsach / Switzerland
Phone +41 (32) 332 77 77, Fax +41 (32) 332 77 88
www.digimesa.com

General Description

The EPI flowmeter is specifically suitable for fluid flow rate measurement of highly viscose media such as syrup, oil or detergent concentrates. Thanks to its special design and the epicyclic wheels, the EPI flowmeter is highly precise and allows extremely accurate flow measurement with minimal pressure loss.

Specific applications: Highly viscous media, high temperatures, high flow rates with low pressure loss and good chemical resistance.

Approvals / Standards

EN55014-1:00+A1:01+A2:02, EN61000-6-3:01+A11:04, IEC61000-6-3:06(ed.2.0), EN61000-3-2:06, IEC61000-3-2:05(ed.3.0), EN61000-3-3:95+A1:01+A2:05, IEC61000-3-3:94+A1:01+A2:05(Cons.ed 1.2), EN55014-2:97+A1:01, EN61000-6-1:01, IEC61000-6-1:05(ed.2)



Material:

Housing: PEEK 150 GL 30 natur
 Bearing pin: Inox 1.4435
 Aluminium oxide on request
 Nozzle: Ø 7.0mm like housing
 O-ring: FPM (Viton)
 EPDM on request
 Turbine: PEEK
 Magnets: NdFeB (Neodym)
 (not contact with the medium)
 Screw: PT-screw
 (Phillips cross recessed)

Technical data:

Flow rate: 0.06 - 5.35 l/min
 Continuous operation: < 500 rpm
 Measuring accuracy: +/- 1.0% *
 Repetition: < +/- 0.25%
 Temperature range: -10°C to +65°C
 14°F to 149°F
 Pressure range: 10 bar at 20°C
 145 psi /68°F
 Mounting position: Horizontal *
 Nozzle size: Ø 7.0 mm
 Viscosity range: approx. 5 - 5000 centistokes

Electrical connection ratings:

Power supply: +3.8 to +24 VDC
 Consumption: < 8 mA
 Signal connection: Open collector NPN
 Signal voltage: 0 VDC GND
 (saturation < 0.7 V)
 Signal load: max. 20 mA
 Leakage current: max. 10 µA
 Connections: 3Pin- AMP 2.8 x 0.8 mm
 Signal: Square-wave output
 Duty Cycle: ~ 50%

* Accuracy in the linear range for individually calibrated equipment

Dimensions in mm:

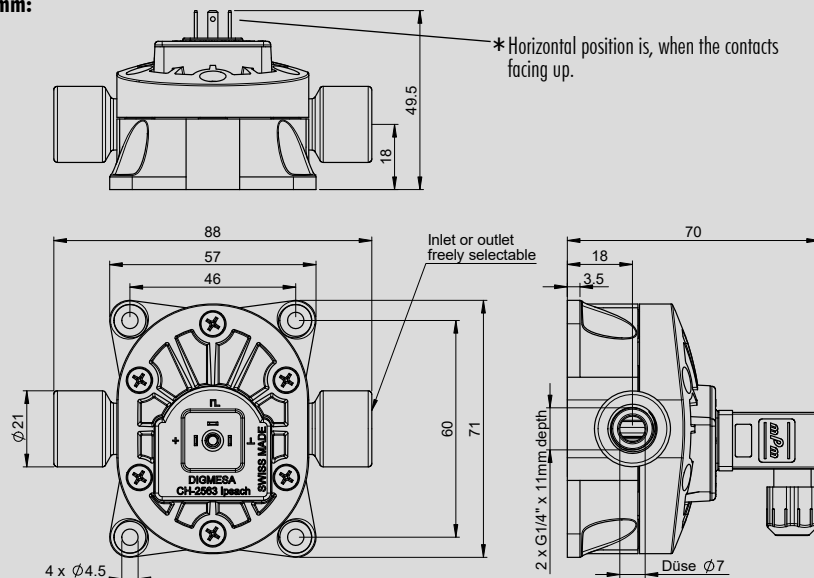

Included in the delivery:

3-pin valve connector
 Item number: 941-0010-3

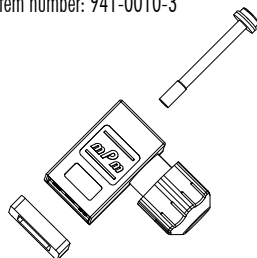

Änderungen im Sinne eines technischen Fortschritts behalten wir uns vor.

RESISTANCE

Special regulations which must be complied with by the flowmeter manufacturer apply to each country, e.g. CE, NSF, FDA and SK. The various media flowing through the flowmeter differ from application to application. You are advised to enquire with the medium manufacturer as to whether the entire installation and the flowmeter are resistant to the medium itself (see Material)!

ELECTRONIC

DIGMESA electronic circuitry is always designed for operation with DIGMESA flowmeters. Please note the following if connecting to other electronic circuitry:

- The flowmeter does not supply an output voltage but switches the signal terminal to 0 V ground (actuated) or leaves it open (non-actuated)
- There must be a pull-up resistor between power supply + and signal depending on electronic circuitry!

Version 04 EPI PEEK 930-0201-V01 GB Page 2-4

Interface Connection: Examples Open Collector

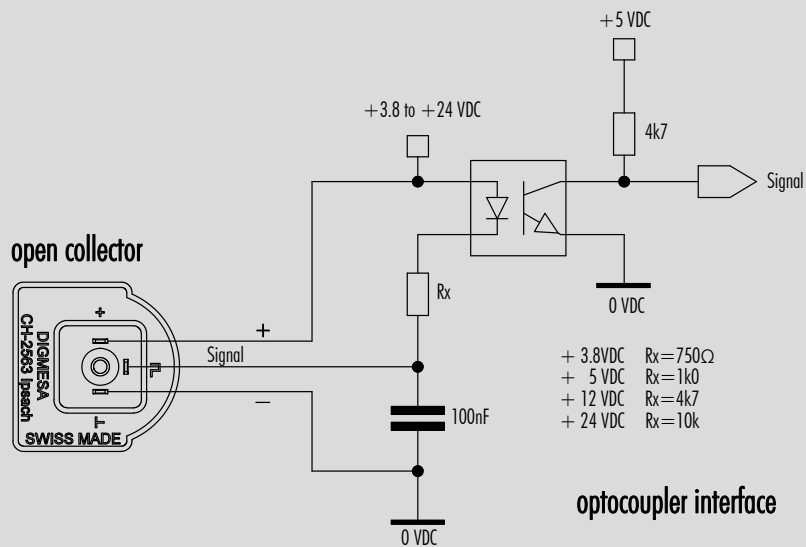
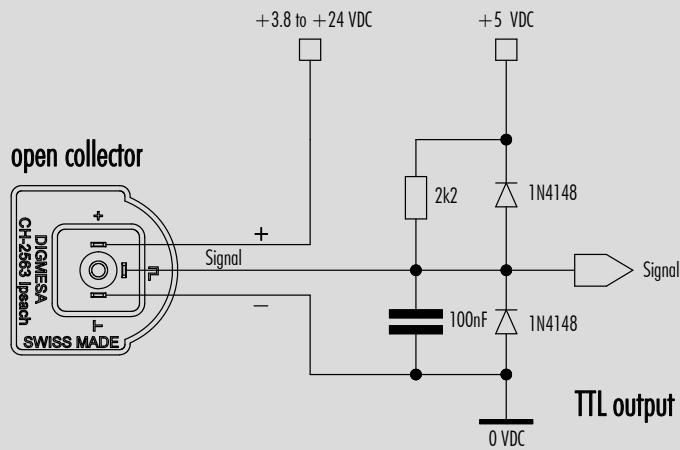
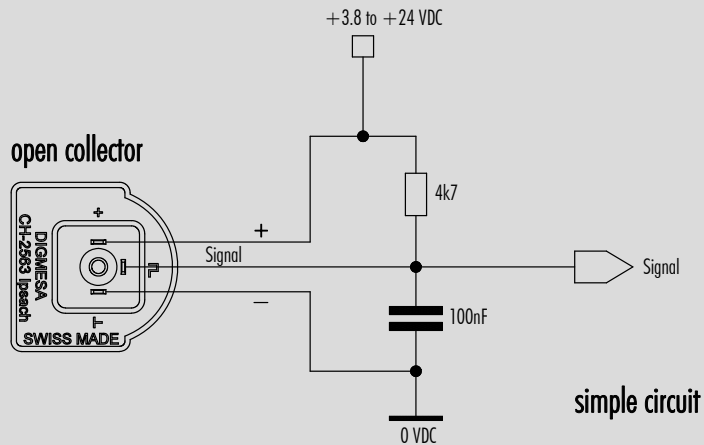

Measurement Curve EPI Ø7.00mm

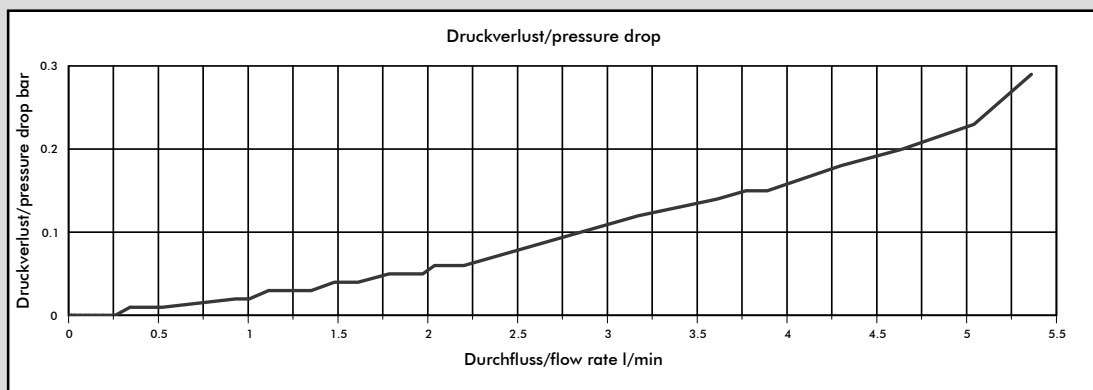
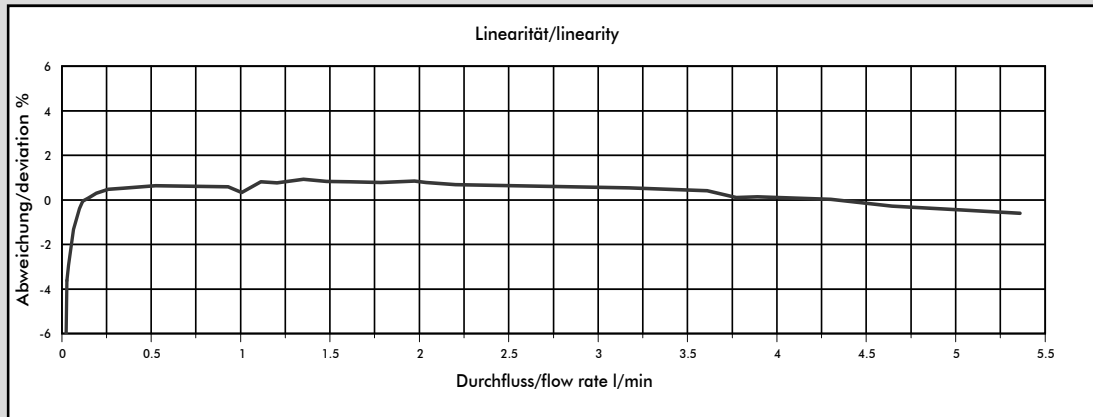

Medium for these linearity and pressure loss curves: Cola syrup (approx. 24 centistokes).

Nozzle size	Pulses/litre	g/pulse	min. flow rate in [litres/min] at linear start	max. flow rate in [litres/min]	Pressure loss in [bar]
Ø 7.00 mm	462	2.1	0.06	5.35	0.29

MEASUREMENT TIPS

- Ensure that there is no fast-pulsatory movement of the media
- Ensure that there are no reverse pressure surges
- Ensure that there is no air in the system
- Keep the pressure loss as small as possible
- Note the mounting position of the flowmeter
- Min/max flow should be in the linear range of the selected flowmeter
- Clean the system at appropriate intervals
- Avoid electrical current peaks
- Incorrect cabling of power supply +, signal and ground will destroy the flowmeter
- Do not mechanically load electrical contacts
- Avoid moisture on the electrical contacts
- Avoid stray pick-up via the cable (Do not lay cables in parallel with high current loads)

The values specified must be considered as approximate values.

The number of pulses per litre may differ depending on medium and installation.

We recommend to calibrate the number of pulses per litre in line with the complete installation.